

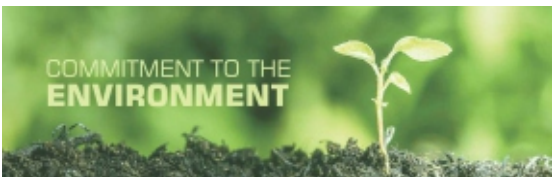

---

**COLLAB SEATING**





### **Commitment to the environment**

Every Shearling product reflects our strong commitment to environment protection. All products confirm to Euro II norms and are free from AZO and PCP contents.

# FURNITURE

## WHAT IS COLLABORATIVE









Collaborative Furniture is specifically crafted to support creativity, boost brainstorming, and promote discussion for a group of people. Collaboration Furniture addresses the need for teamwork without forcing your patrons to move chairs or rearrange your space. This creates a welcoming and innovative atmosphere that is perfect for addressing modern needs.

# IMPORTANCE

Collaboration Furniture is a crucial aspect of supporting the needs of those who use your space on a regular basis. While understanding spaces and designing furniture, we've noticed something, Creating Furniture to support actual patterns of use is the most effective way to ensure a space is utilized as it's intended. In other words, it's important to thoughtfully consider how people will move, learn, and interact in the space you provide.

Whether it's in a Corporate Office, Library, University, or other public space, modern Collaboration Furniture is Multifunctional, Versatile, and Accommodates all patterns of use, including the ability to choose how we work without needing to move our belongings to the chair across the room, pull tables together, or sit on the floor.



Sr. No.	Model	Image	Pg. No.
1	ALKOVE		5
2	DNA		9
3	AZ		13
4	MD		17
5	EASE		21
6	CIRCLE		25
7	ENCORE		29
8	ZELIG		33
9	ACP		37

# ALKOVE

Alkove is designed to form an array of combinations suitable for even the most diverse environments. It delivers a striking, all-encompassing solution for today's modern office or educational environment. A compact size makes the system genuinely versatile and adaptable for use in both small and open spaces.



## Product Details

**Back Panel :** The substructure is made of plywood and solid wood

**Category :** Seating

**Environment :** Indoor

**Materials :**

Upholstery - Polyurethane Foam with timber substrate upholstered

**Optional Add-ons :**

Floor fixing bracket power & data integration



**Upholstery :**



Fabric



Vinyl



Leather



ALK-01 ALK-03 ALK-02

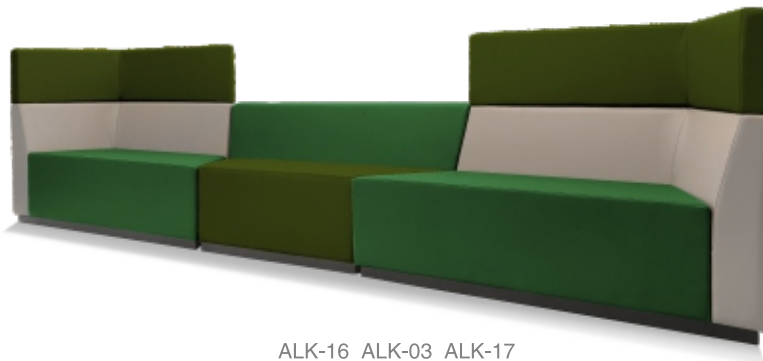

ALK-16 ALK-03 ALK-17



ALK-16 ALK-03 ALK-17



ALK-16



ALK-03



ALK-17

## Seat

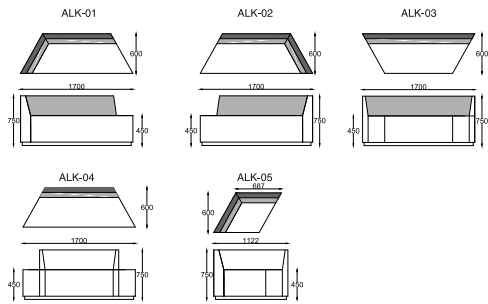

## Ottoman

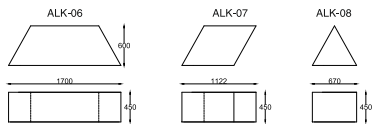

## Side Table

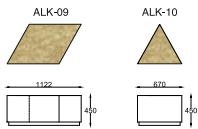

## Medium Backseat

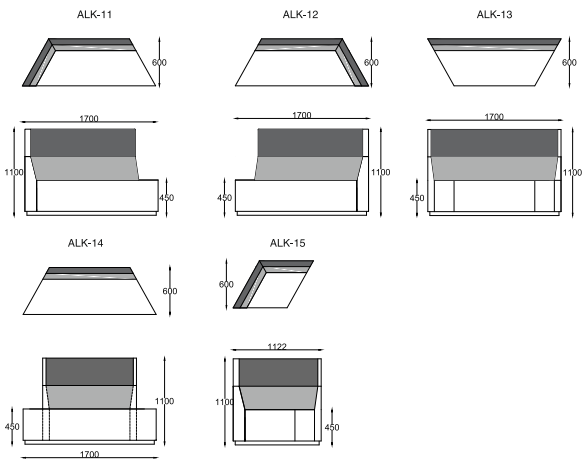

## High Backseat

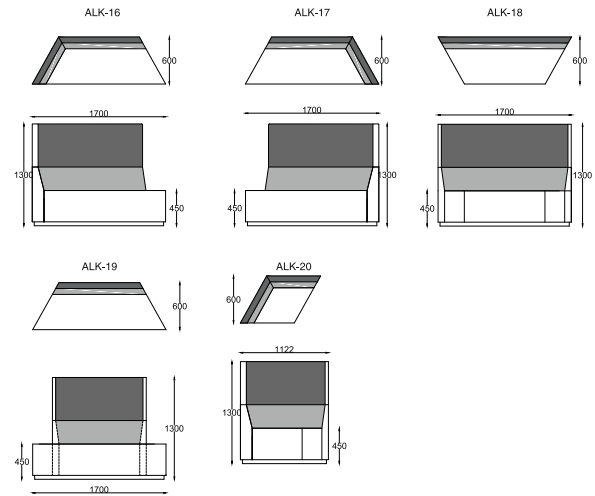

## 2 Person Workbooth

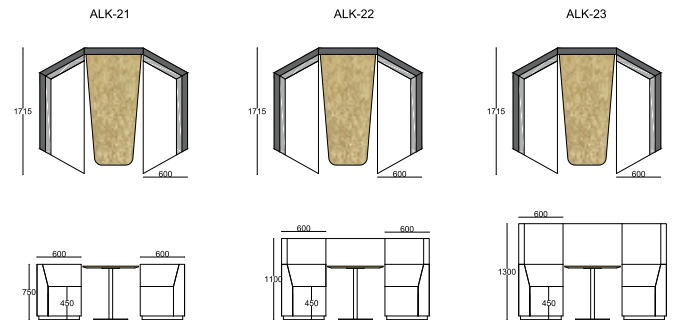

## 4 Person Workbooth

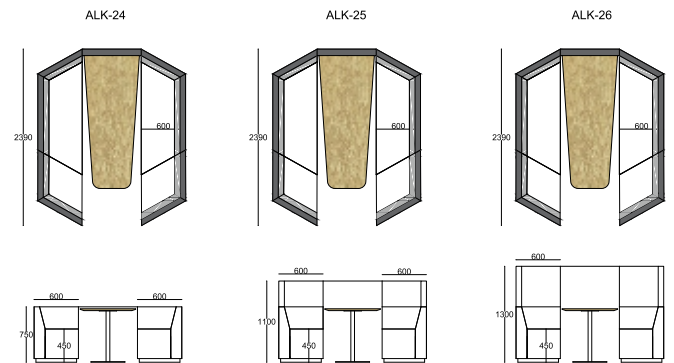



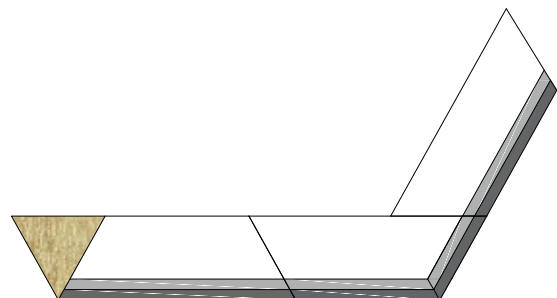
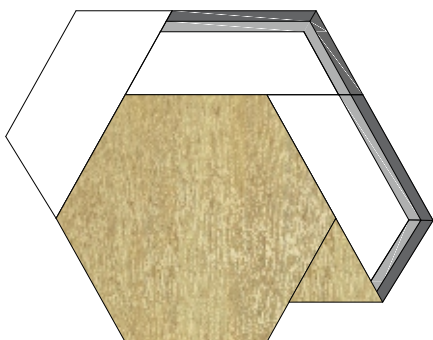
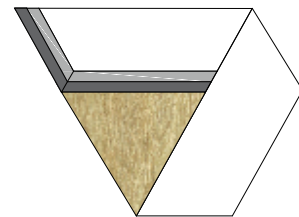
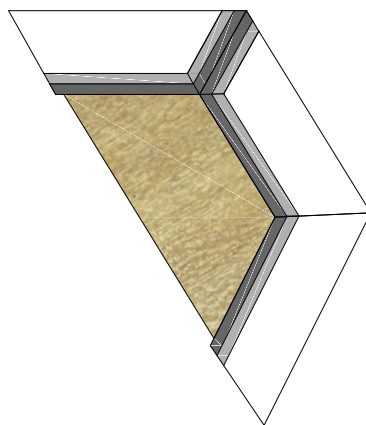
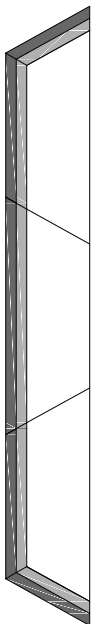
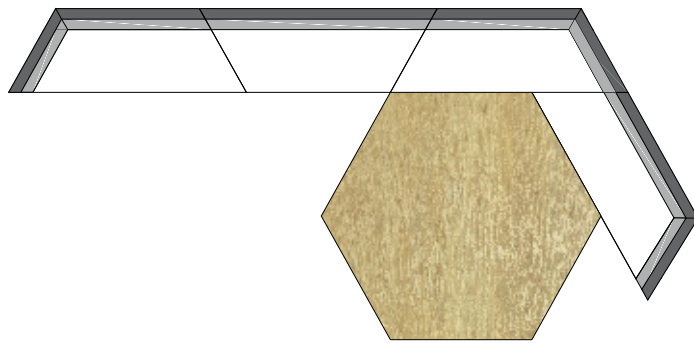
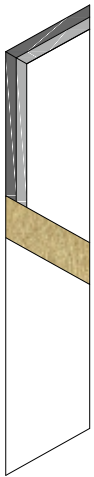

# DNA

DNA is based on infinite combinations, round or angular the end element gives a overhang look to the combination, Table can be integrated to add extra space for Magazine, Coffee Cup or Laptop working. This is a great space filling concept with modular formats.



## Product Details

**Structure :** The substructure is made of plywood and solid wood

**Category :** Seating

**Environment :** Indoor

**Materials :**

Upholstery - Polyurethane Foam with Timber substrate upholstered

**Optional Add-ons :**

Power & data integration



**Upholstery :**



Fabric



Vinyl



Leather



CR-02 CR-03

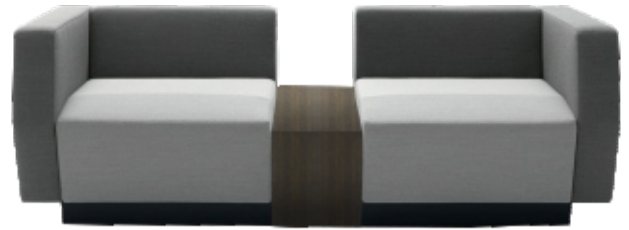

CR-02 CR-10 CR-03



CR-07 CR-01 CR-01 CR-05 CR-08 CR-07



CR-06 CR-10 CR-01 CR-05 CR-01 CR-07



CR-07 CR-10 CR-01 CR-01 CR-10 CR-07

Seat with Back

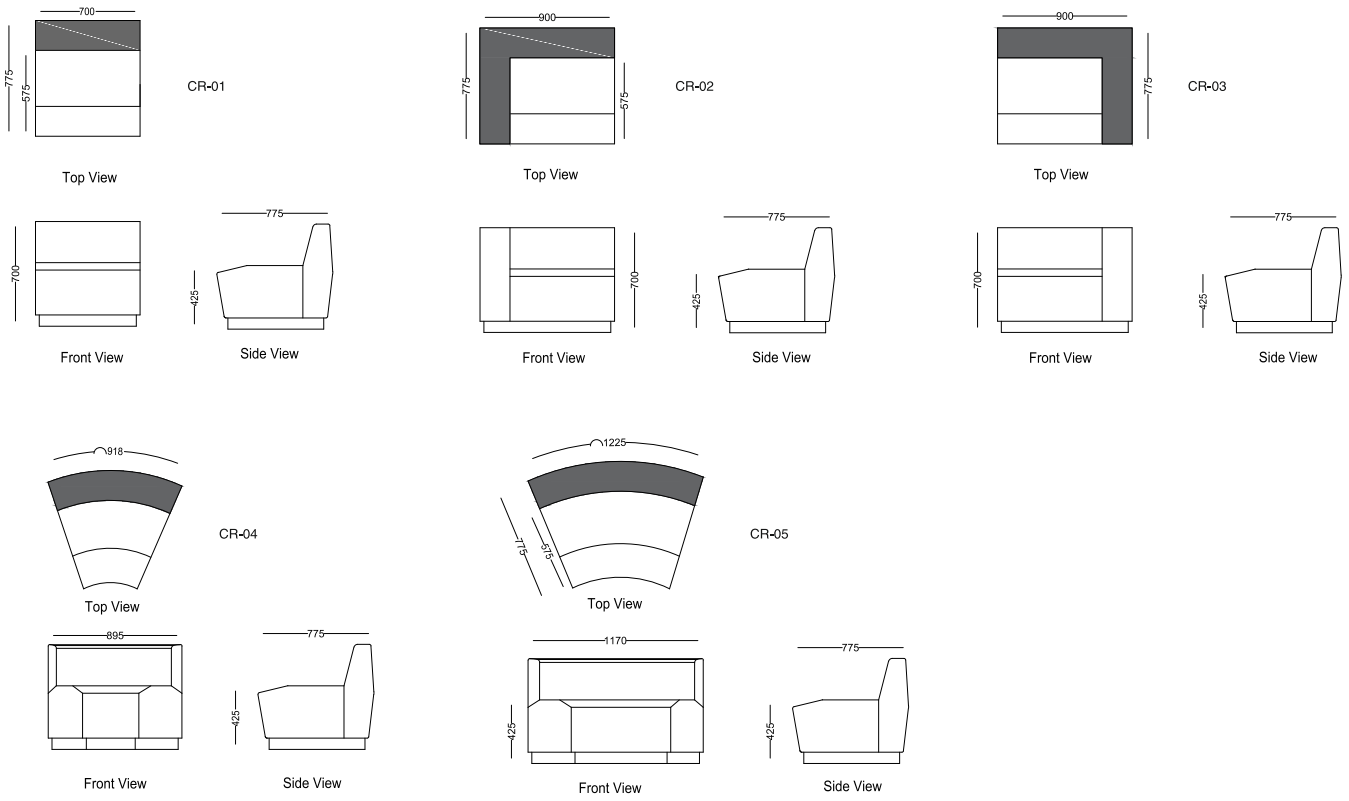

Ottoman (Banches)

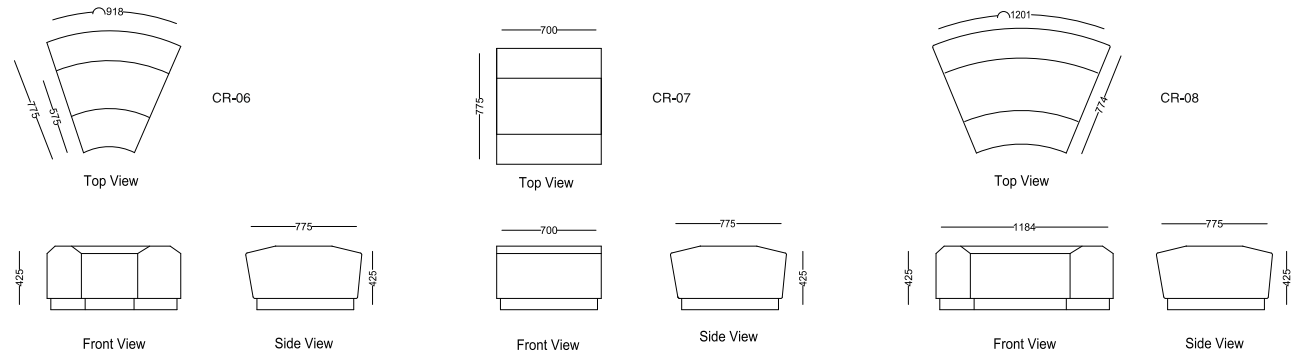

Side Table

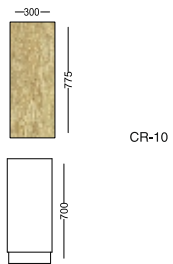

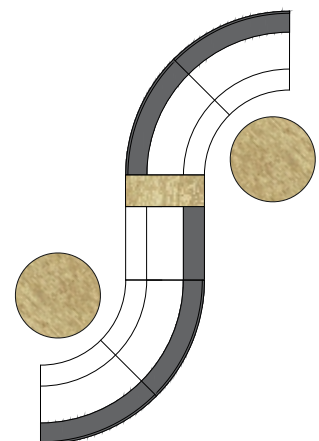
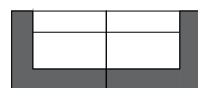
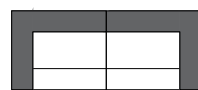
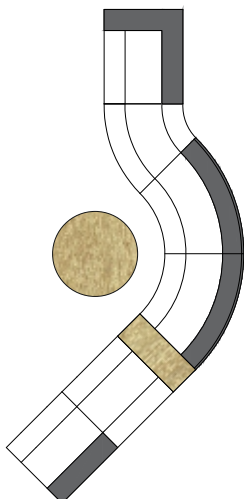
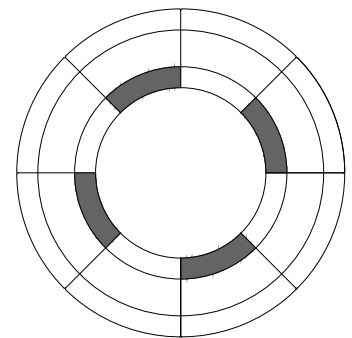
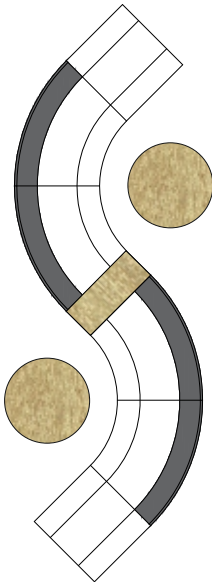
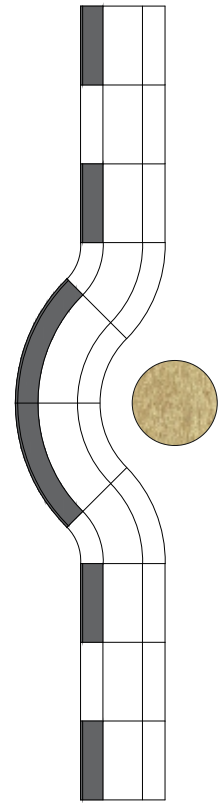
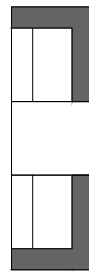
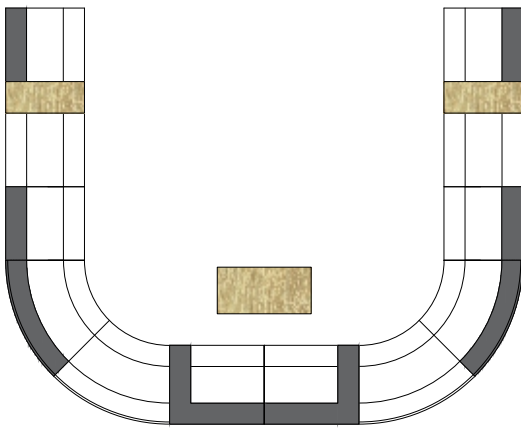

# AZ

AZ is ideal for refuge areas in an office, acoustic soft seating for the spaces can be created without solid Partations, either a meeting area, desk for working or a simple reception seating without acoustic enclosure, the product is versatile in usage.



## Product Details

**Back Panel :** Acoustic properties with plywood frame reinforced with polyplex foam.

**Seat:** Solid Wood and Plywood structure, High density foam, firm seating comfort.

**Environment :** Indoor

**Materials :**

Upholstery - Polyurethane foam, acoustic panels, polyplex form, upholstery, metal legs in Stainless Steel or Colored.

**Optional Add-ons :**

Power and data integration  
Screen and table for Meeting



**Upholstery :**





A-24 A24



A-25 A25 A25



A-25 A25 A25



A-22



A-21



A-23

# AZ Overview & Dimensions



A-21

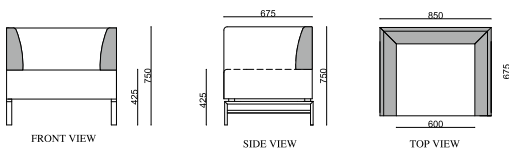

A-22

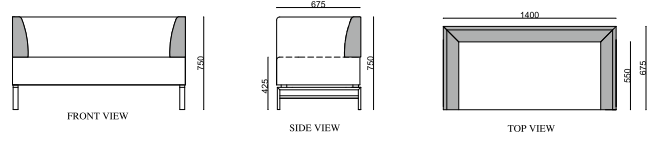

A-23

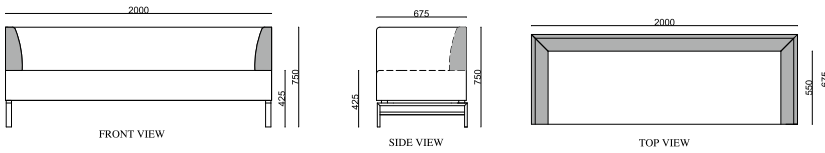

A-24

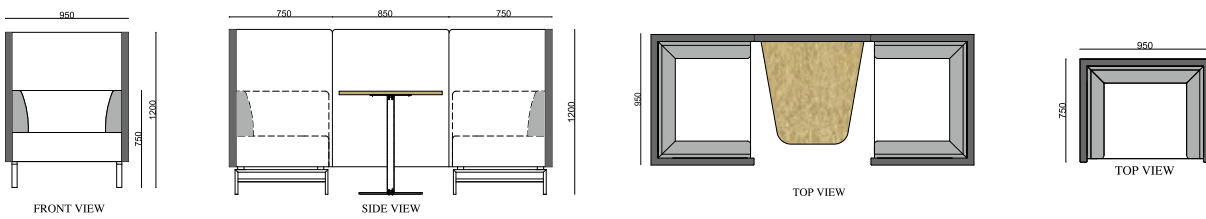

A-25

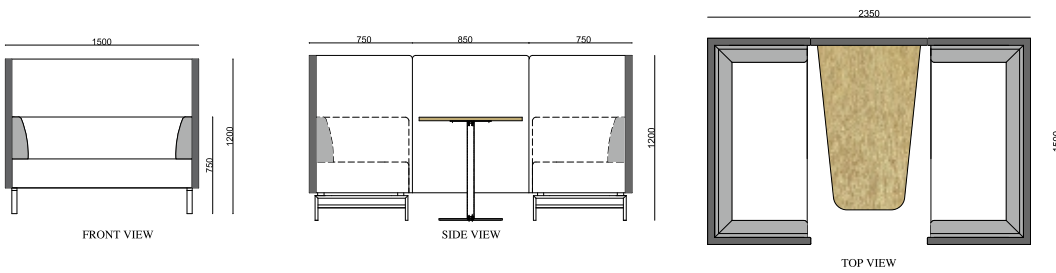

A-26

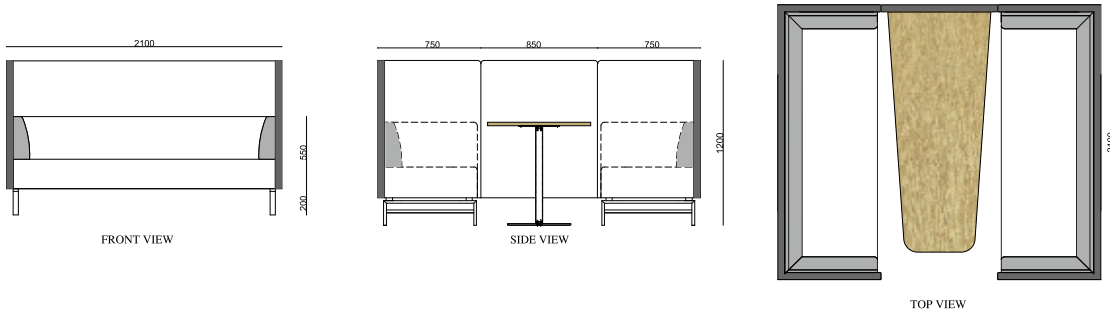

A-27 (Encloser)

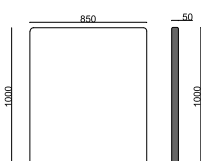



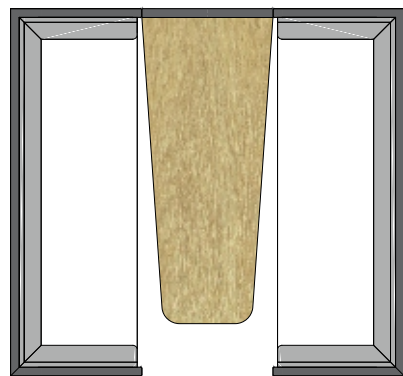
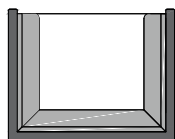
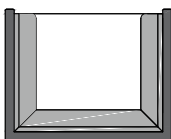
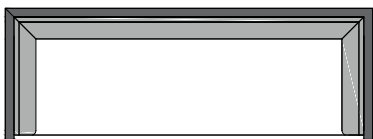
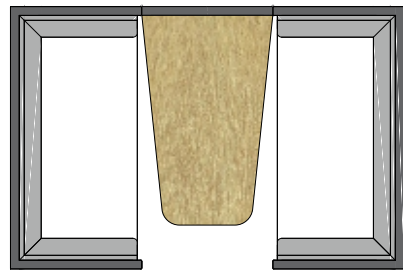
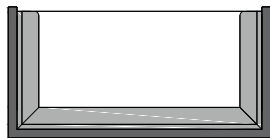
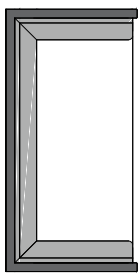
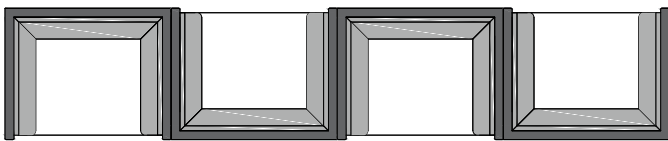
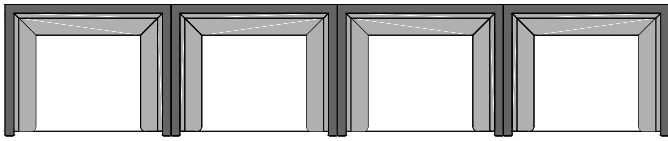

# MD

MD is an office COLLAB System that combines design and technology, to create a versatile and elevating operating positions that provide mobility in the work spaces. Made with high quality materials its structure conceals the great solidity while giving the product a light and functional aesthetics. The ribbed angled bracket supports the table improves the functionality of the product, making more active and dynamic spaces.



## Product Details

**Seat and Back :** The substructure is made of plywood and solid wood with metal reinforcements

**Category :** Seating

**Environment :** Indoor

**Materials :**

Upholstery - Option of Vinyl, Leather and Fabric

**Optional Add-ons :**

Power & data integration



**Upholstery :**



Fabric



Vinyl



Leather

**Back Panel :** In steel with RIBS joined through intergration

12 Person, Meeting Zone with Acoustic Writing Board



MD-04 MD-04 MD-04

6 Person, Meeting Zone with Acoustic Writing Board



MD-02 MD-02 MD-02



MD-04 MD-04 MD-04



MD-02 MD-02 MD-02

2 Module with arm  
(without back)

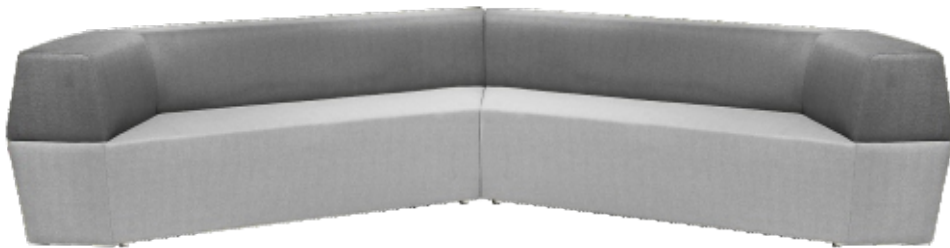

MD-05 MD-06



MD-05 MD-06



MD-05 MD-07 MD-06 MD-07

1 Module (with back)

1 Module (without back)



MD-04

MD-02

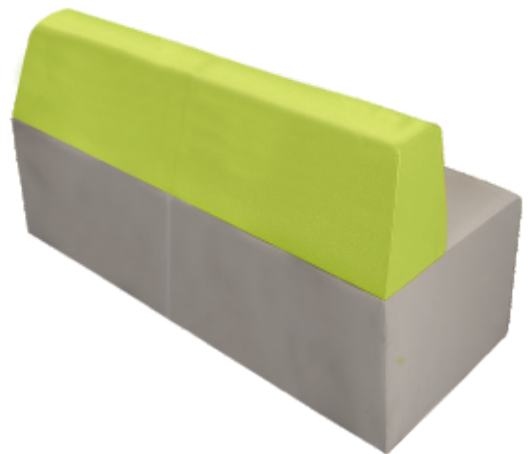

MD-04

MD-02

MD-01

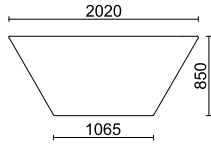

MD-02

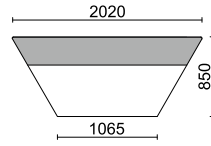

MD-03

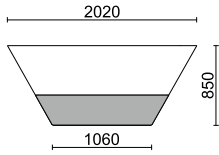

MD-04

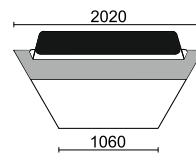

MD-05

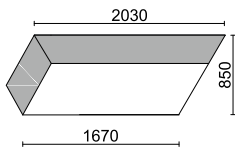

MD-06

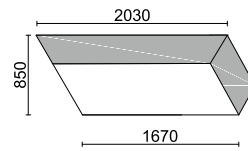

MD-07

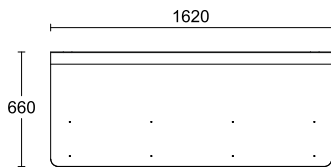

Front View

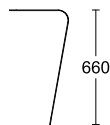

Side View

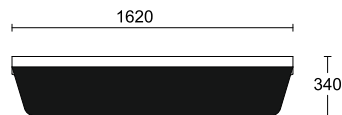

Top View

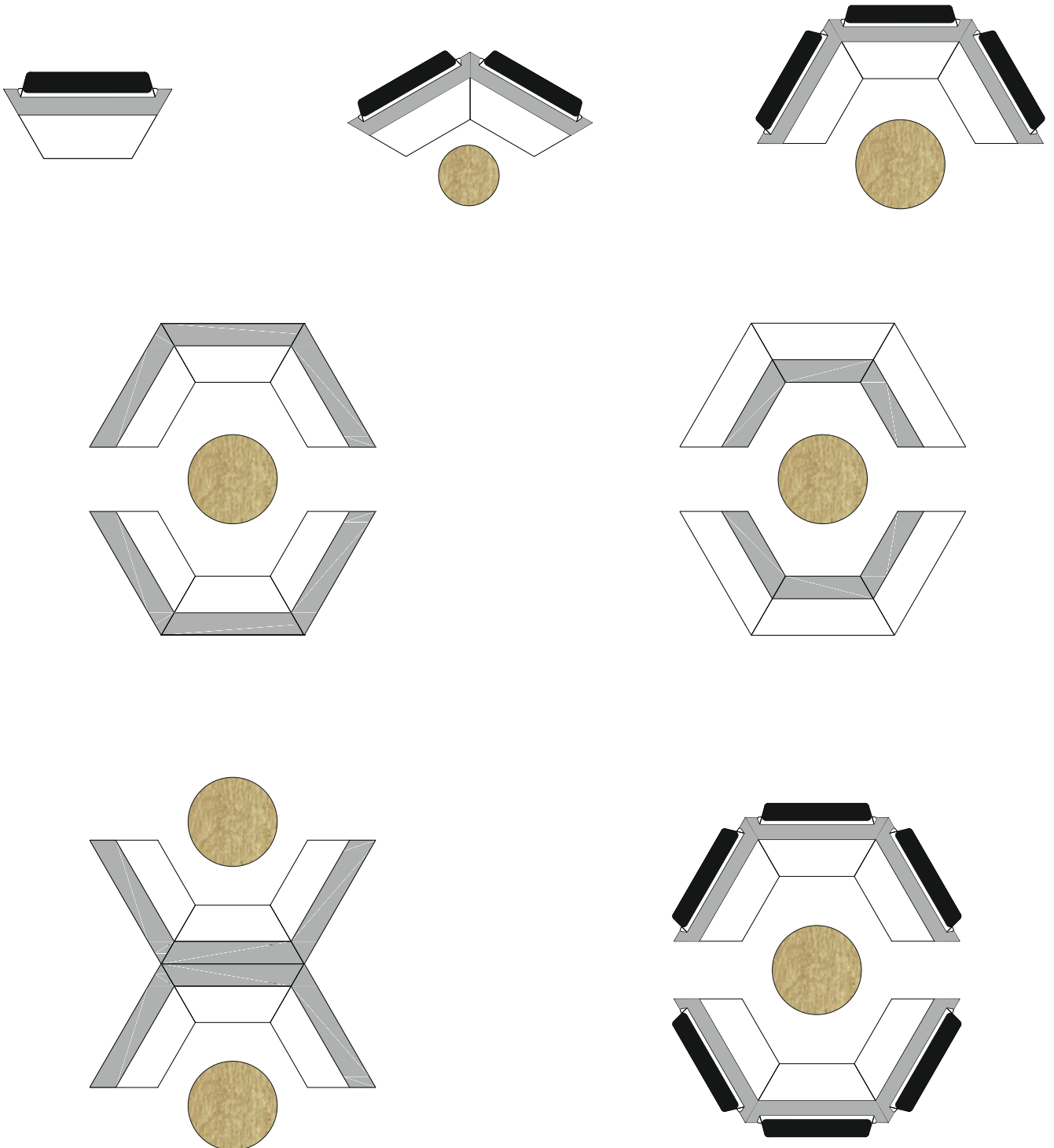

# EASE

Ease is a set of seats which when joined together can create different Ambience's and Environments. Its ideal for common spaces. A combination that inspires creativity and personalisation. It's open nature is to grow and evolve and to mutate in search of new shapes for individual users.



## Product Details

**Seat and Back :** The substructure is made of plywood and solid wood with metal reinforcements

**Category :** Seating

**Environment :** Indoor

**Materials :**

Upholstery - Option of Vinyl, Leather and Fabric

**Optional Add-ons :**

Power & data integration



**Upholstery :**



Fabric



Vinyl



Leather

**Back Screen :** In steel with joined through intergration





EA-09



EA-07 EA-07

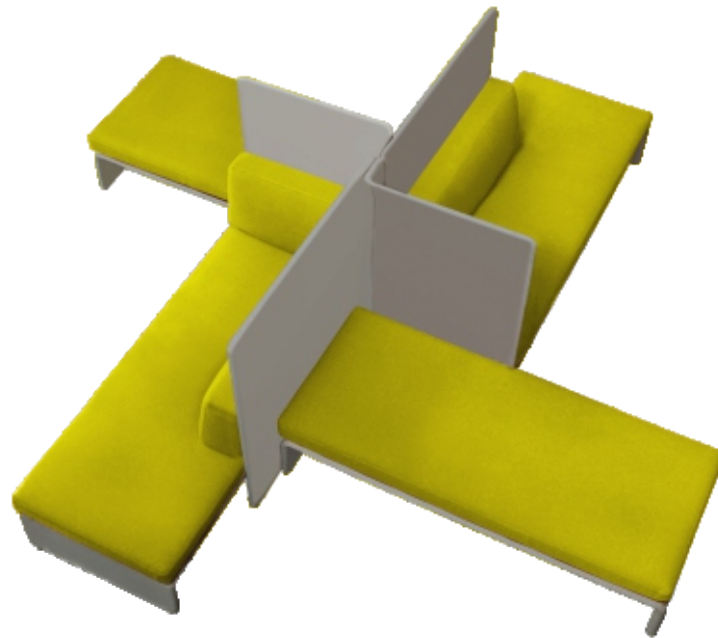

EA-11 EA-03 EA-11 EA-03



EA-11 EA-11



EA-08 EA-08

## Without Back

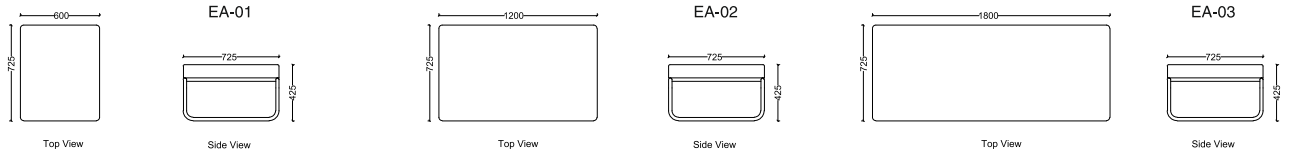

## Ease Sofa With Back

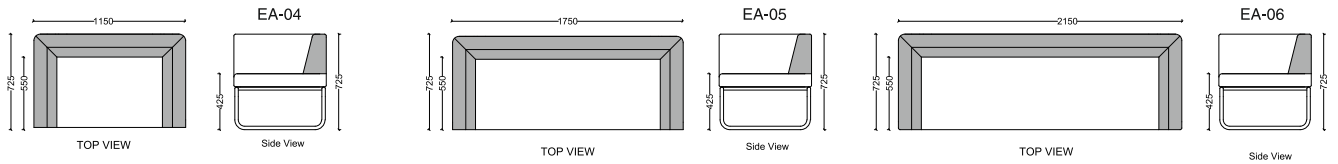

## Ease Sofa With Back & Screen

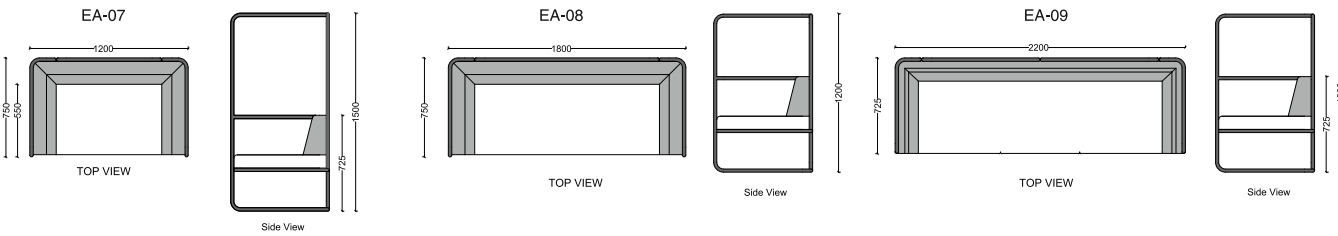

## Ease Sofa Half Back & Screen

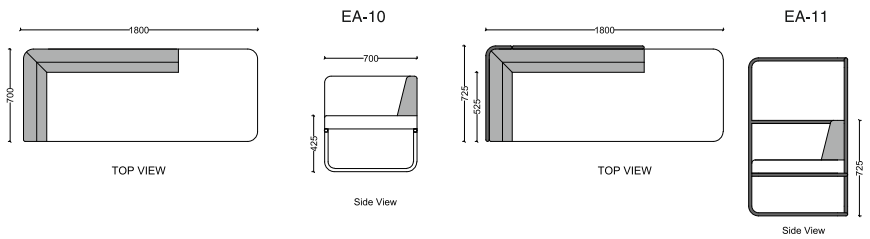

## Ease Sofa only Back

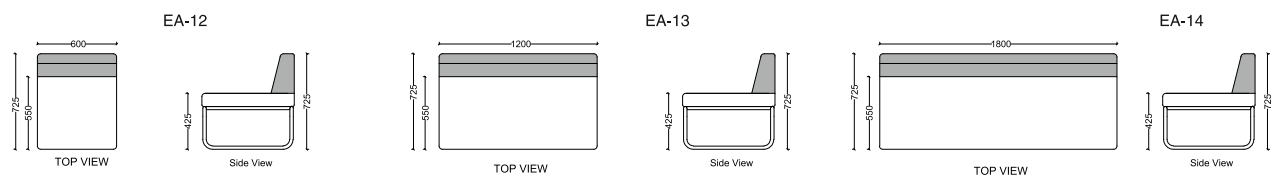

## Ease Sofa with Back & Screen

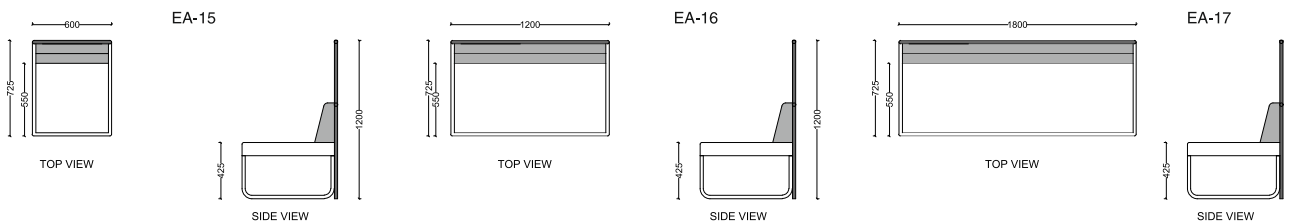

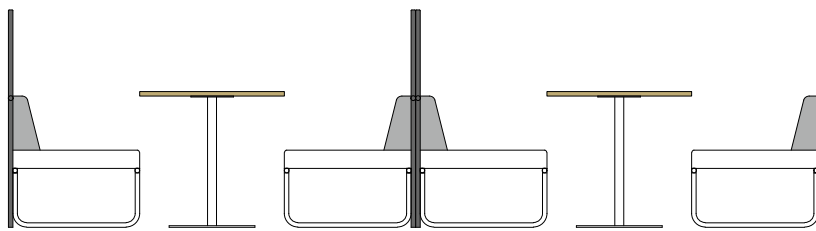
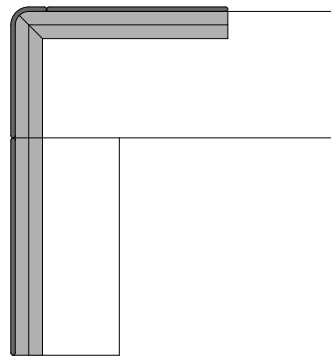
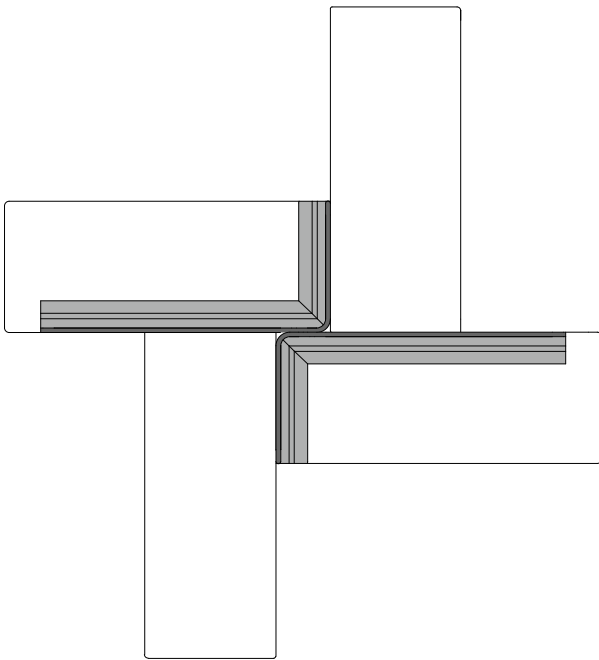
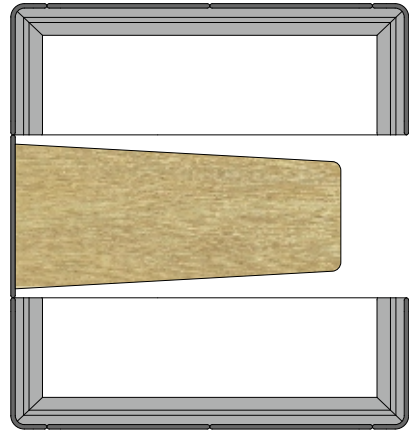
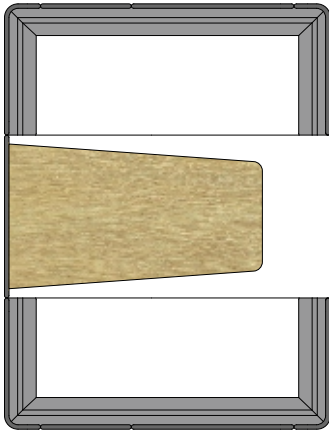

# CIRCLE

Circle is a set of seats which when joined together can create different Ambience's and Environments. Its ideal for common spaces. A combination that inspires creativity and personalisation. It's open nature is to grow and evolve and to mutate in search of new shapes for individual users.



## Product Details

**Seat and Back :** The substructure is made of plywood and solid wood with metal reinforcements

**Category :** Seating

**Environment :** Indoor

**Materials :**

Upholstery - Option of Vinyl, Leather and Fabric

**Optional Add-ons :**

Power & data integration



**Upholstery :**



Fabric



Vinyl



Leather



CE-05 CE-05



CE-02



CE-05 CE-05

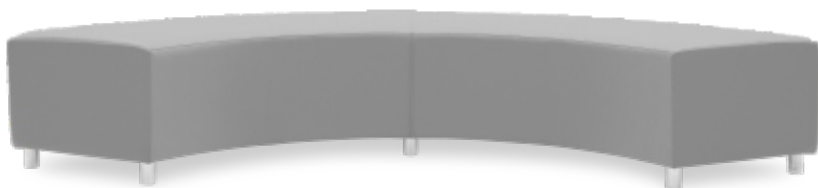

CE-04



CE-04

CE-01

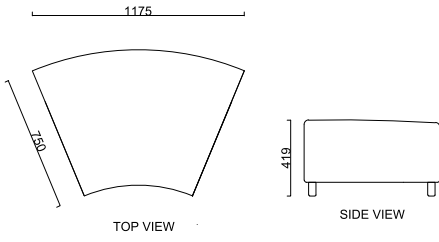

CE-02

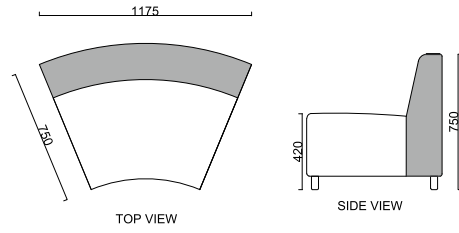

CE-03

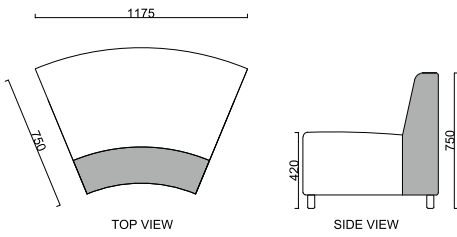

CE-04

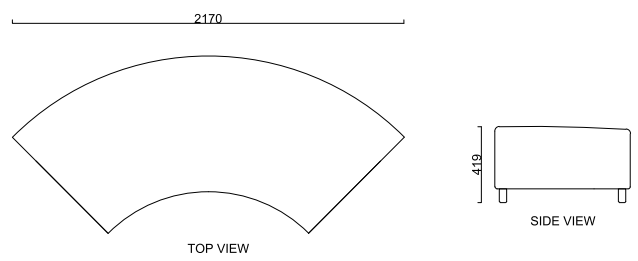

CE-05

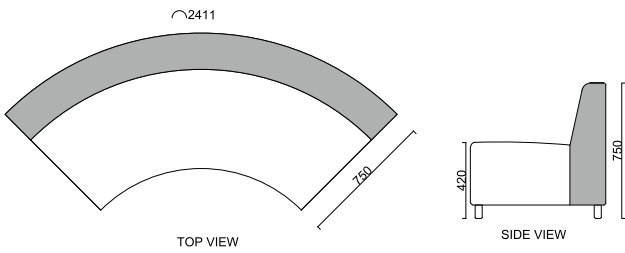

CE-06

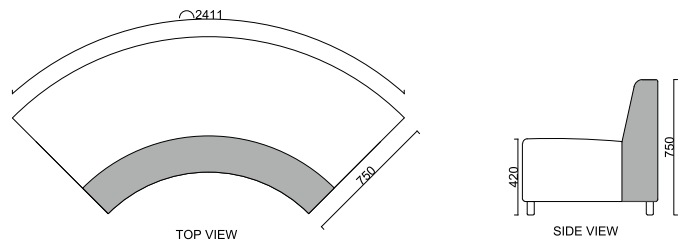

CE-07

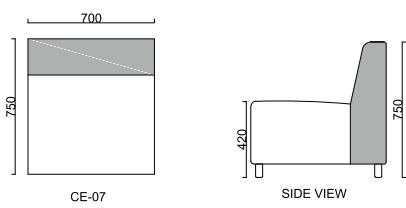

CE-08

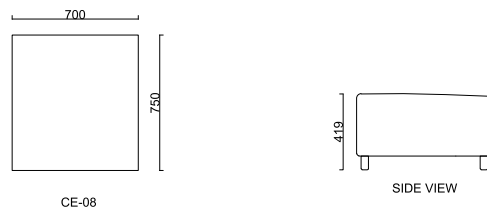

CE-09

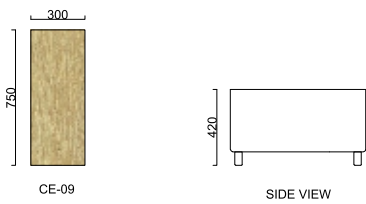

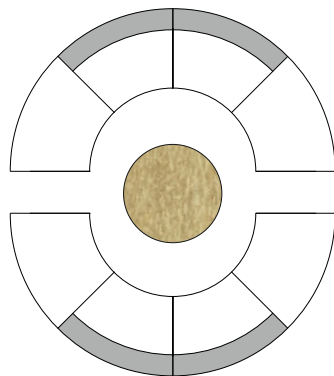
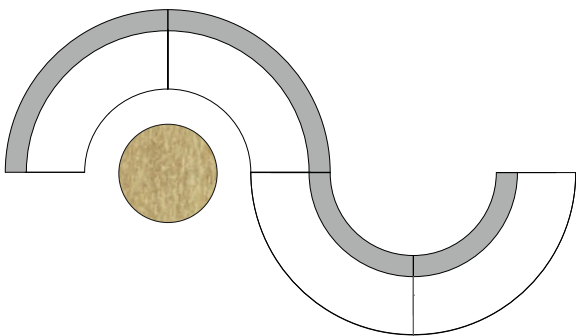
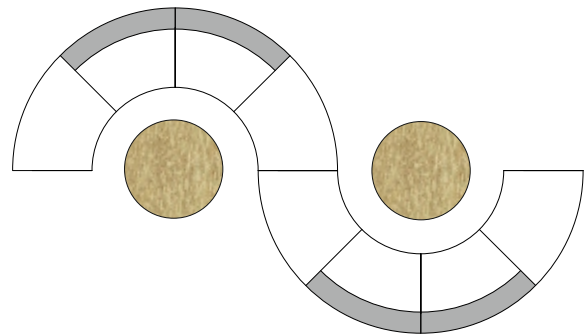
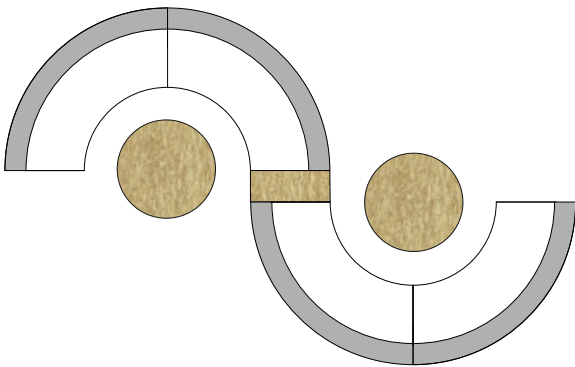
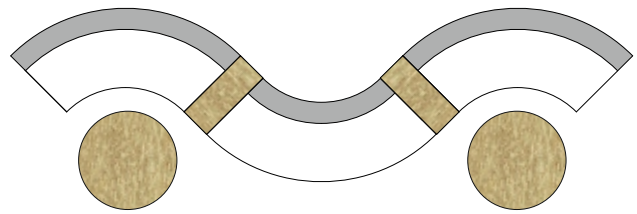
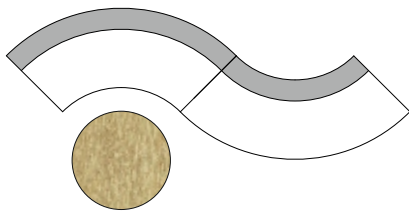
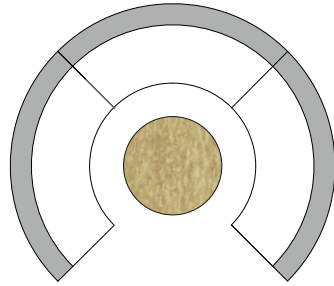
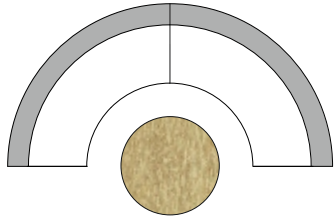

# ENCORE

Encore is ideal for refuge areas in an office, acoustic soft seating for the spaces can be created without solid Partations, either a meeting area, desk for working or a simple reception seating without acoustic enclosure, the product is versatile in usage.



## Product Details

**Back Panel :** Acoustic properties with plywood frame reinforced with polyplex foam.

**Seat:** Solid Wood and Plywood structure, High density foam, firm seating comfort.

**Environment :** Indoor

**Materials :**

Upholstery - Polyurethane foam, acoustic panels, polyplex form, upholstery, metal legs in Stainless Steel or Colored.

**Optional Add-ons :**

Power and data integration  
Screen and table for Meeting



**Upholstery :**





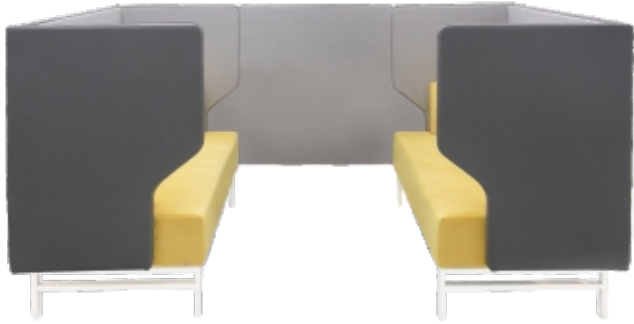

EN-09 EN-09



EN-08 EN-08 EN-08



EN-08 EN-08 EN-08



EN-02



EN-01



EN-03

## Encore Sofa with Back

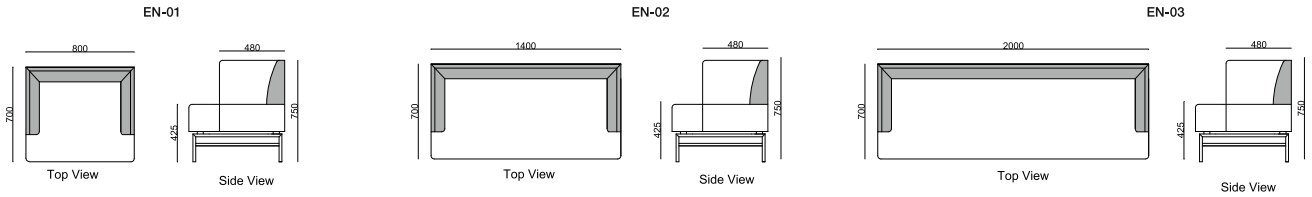

## Encore Sofa with Back & Screen

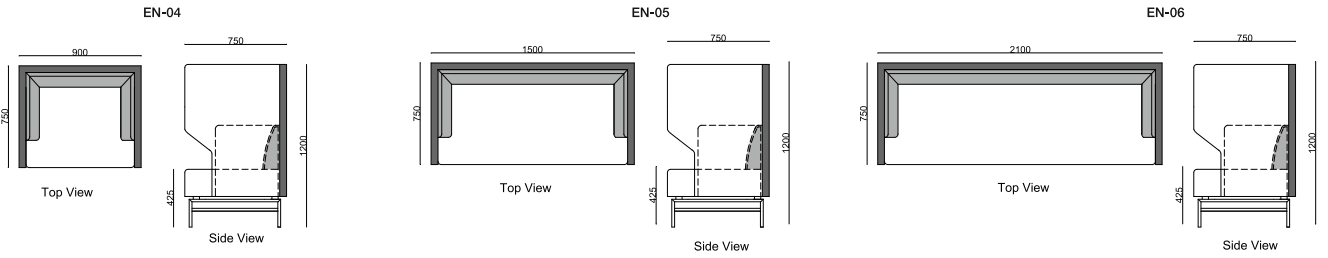

## Encore Sofa with Screen & Table

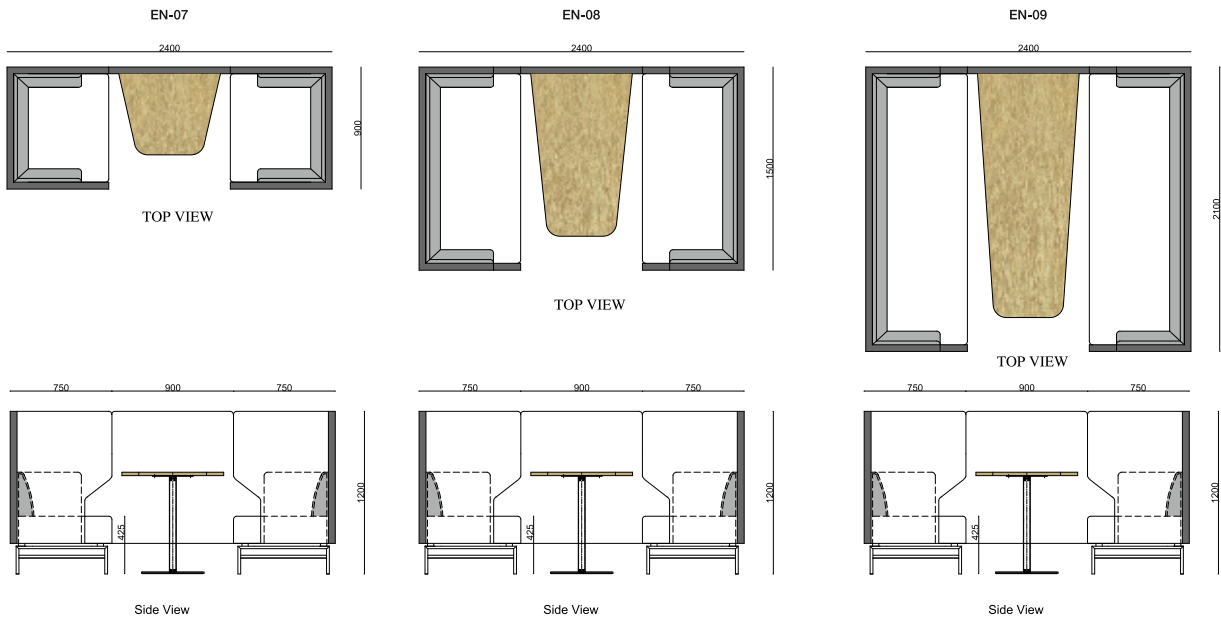

## Encore Sofa Screen



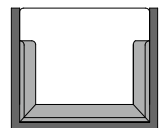
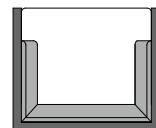
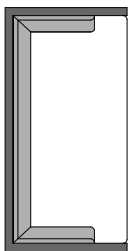
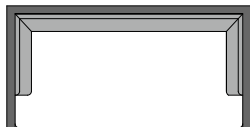
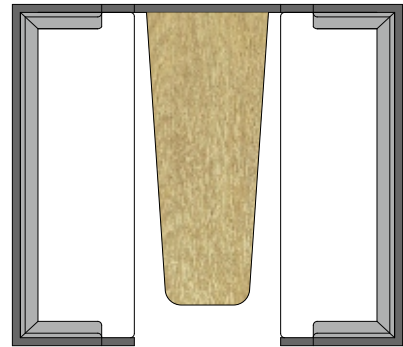
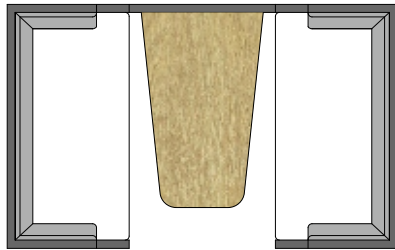
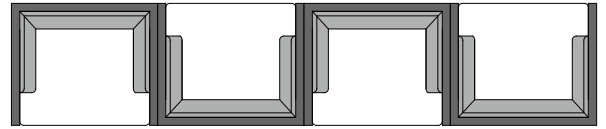
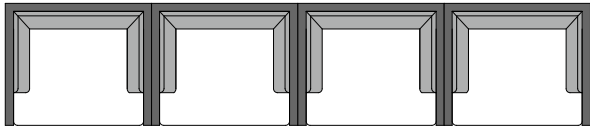

# ZELIG

Zelig is a comprehensive modular programme that transcends the classic concept of waiting area seating. The broad range of elements and accessories available and the special design of the modules allows endless compositions to be configured, transforming waiting areas into collaborative spaces for interaction. Spaces in which to wait or rest, hold meetings or work in a team in a relaxed atmosphere. The collection offers a wide range of seating modules, side units and connectivity accessories that can be combined for adapting to each space.



## Product Details

**Seat and Back :** The substructure is made of plywood and solid wood with metal reinforcements

**Category :** Seating

**Environment :** Indoor

**Materials :**

Upholstery - Option of Vinyl, Leather and Fabric

**Optional Add-ons :**

Power & data integration



**Back Panel :** In steel with RIBS joined through intergrations

**Upholstery :**



Fabric



Vinyl



Leather



ZEL.A ZEL.S ZEL.T



ZEL.A ZEL.S ZEL.A



ZEL.A ZEL.S ZEL.A



ZEL.T ZEL.I ZEL.I ZEL.I ZEL.I ZEL.T



ZEL.I ZEL.I ZEL.I



ZEL.I

ZEL.I

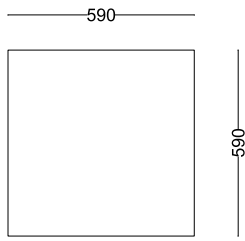

Top View

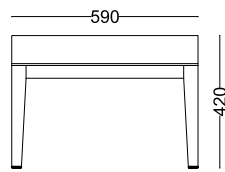

Side View

ZEL.S

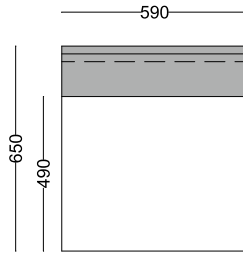

Top View

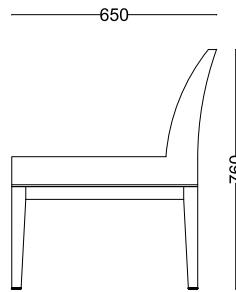

Side View

ZEL.A

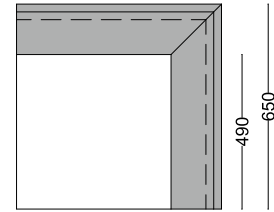

Top View

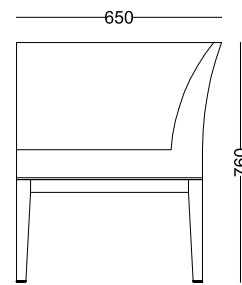

Side View

Table

ZEL.T



Top View

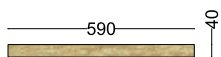

Side View

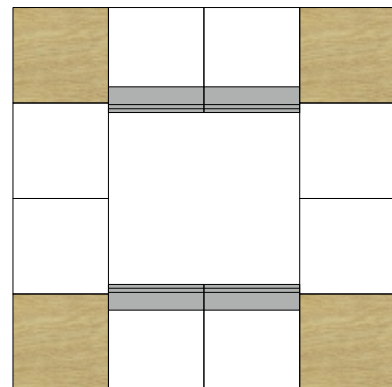
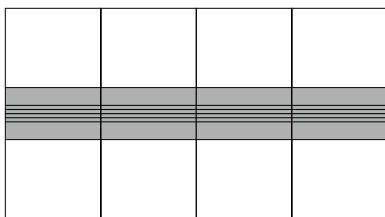
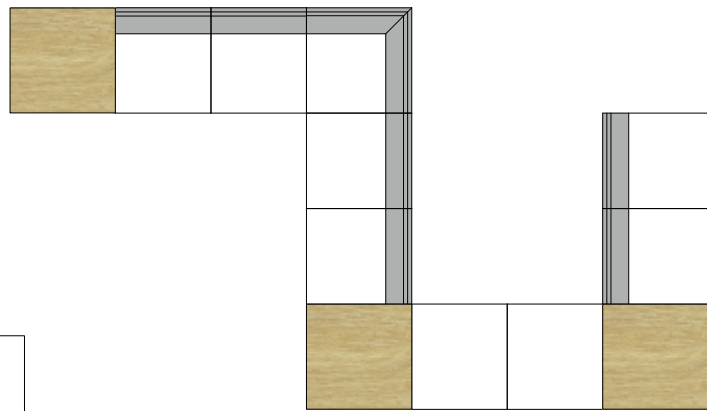
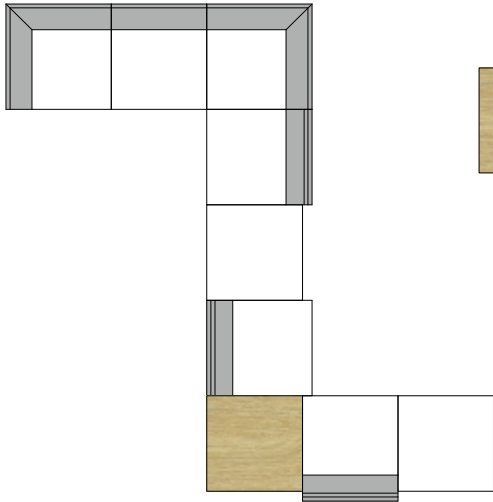
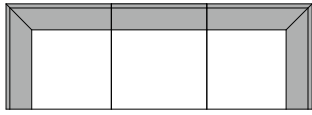

# ACP

ACP is more than a functional element in the office, it's design encourages more spontaneous meetings and creates new opportunities for teamwork. The board is mobile double sided and has an anthracite grey sheet frame with casters.



## Product Details

**Structure:** The main frame is CNC bent sheet

**Category :** Writing Board

**Environment :** Indoor

**Materials :** Laminate Board

**Optional Add-ons :**  
Acoustic Panel

### Upholstery :



Fabric



Acoustic Panel





ACP-01



ACP-02



ACP-03



ACP-03

Movable Writing Board with Castors

ACP

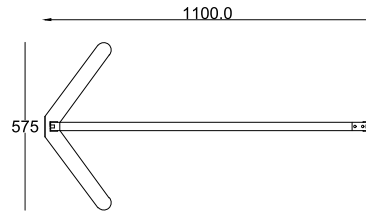
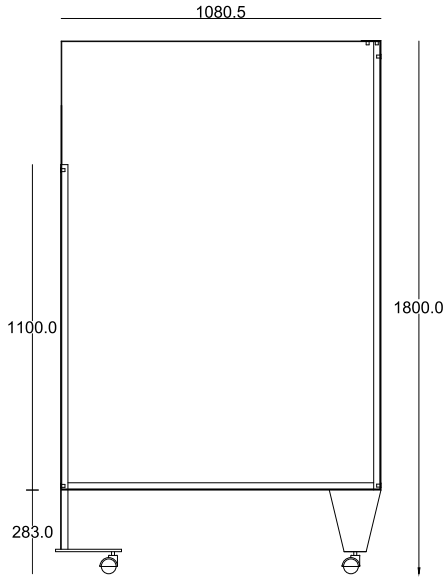



## METAL BASE FINISHES

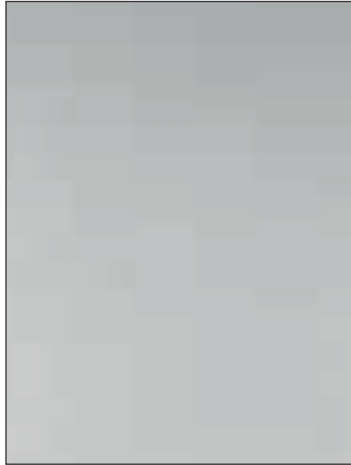

BRUSH FINISH  
SS 2001

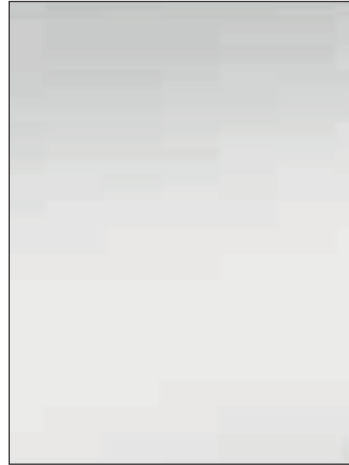

HIGH GLOSS FINISH  
SS 2002

## WOOD STAINS

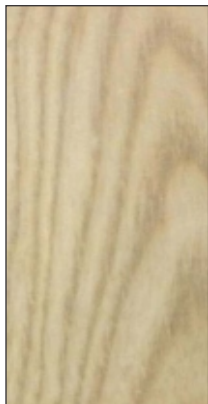

NATURAL WS 9001

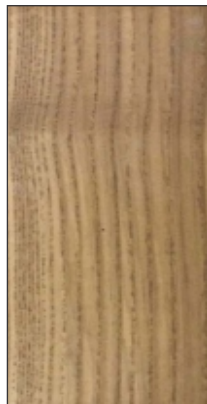

LISBON WS 9002

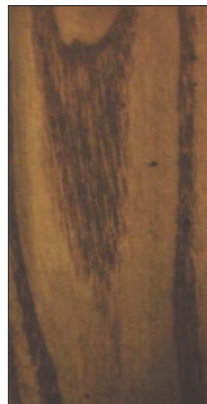

SWISS OAK WS 9003

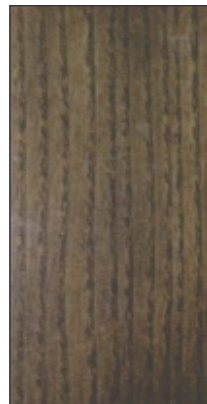

AMERICAN WALNUT WS 9004

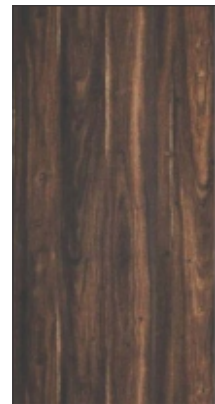

LIRO WS 9005



GLACIER WS 9006

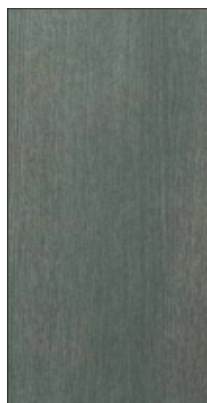

AVIGNON WS 9007

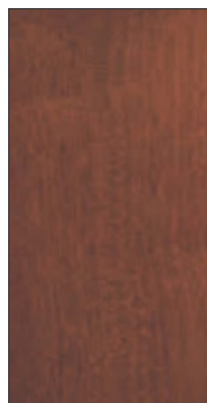

SAPELI WS 9008

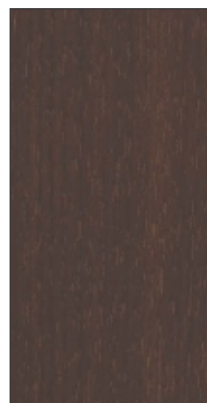

MED. WALNUT WS 9009



DARK WALNUT WS 9010

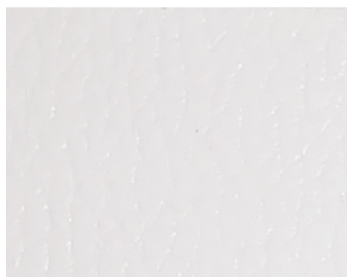

PEARL / AL 901



CREAM / AL 902



THUNDER / AL 903

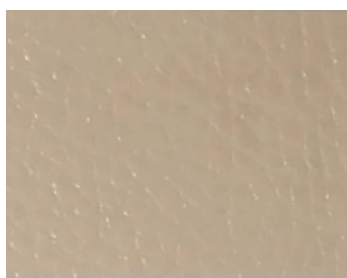

ECRU / AL 904



SEPIA / AL 905

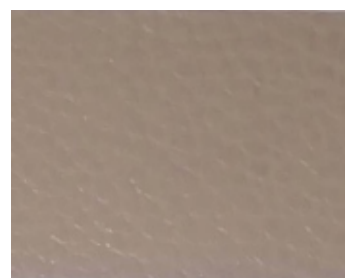

ASH / AL 906



PEANUT / AL 907

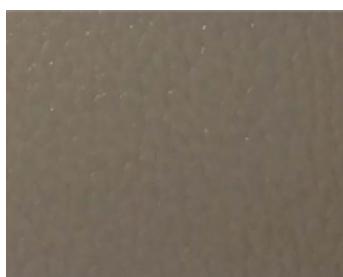

STONE / AL 908



MINK / AL 909



TORTILLA / AL 910

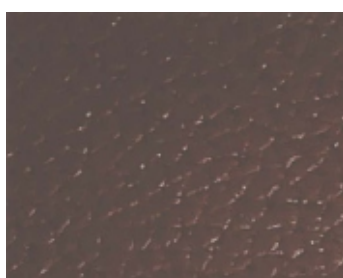

WALNUT / AL 911

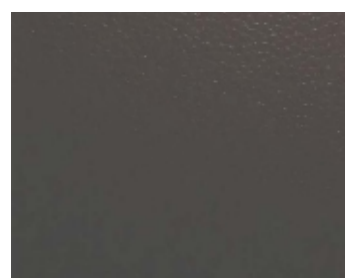

COFFEE / AL 912

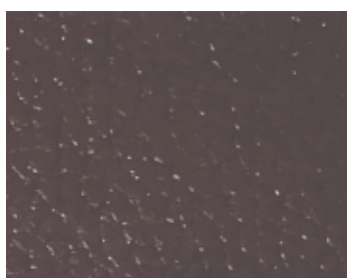

MOCHA / AL 913

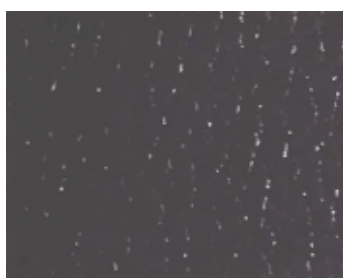

CHOCOLATE / AL 914

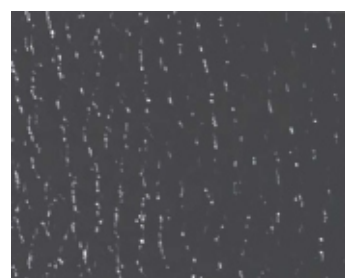

UMBER / AL 915



WOOD / AL 916



CINNAMON / AL 917



BROWN / AL 918

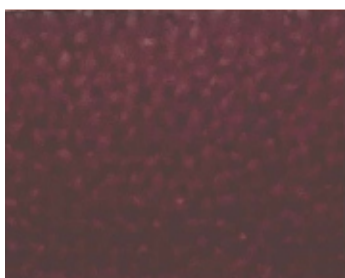

MAHOGANY / AL 919

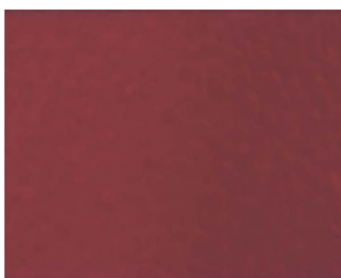

BARN RED / AL 920

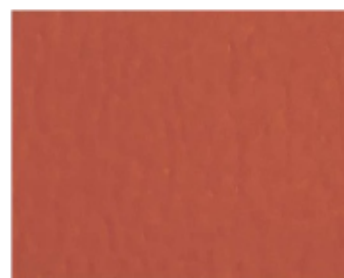

ORANGE / AL 921

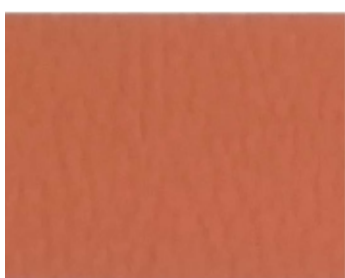

SPICE / AL 922

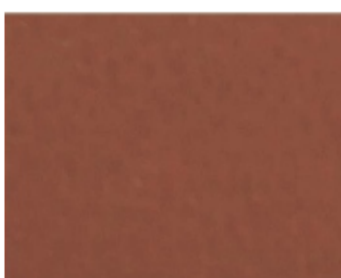

RUST / AL 923

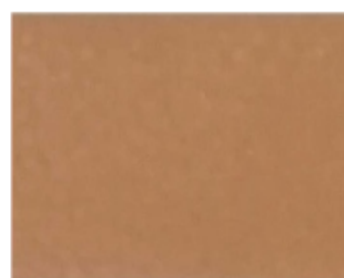

OCHRE / AL 924



CIDER / AL 925

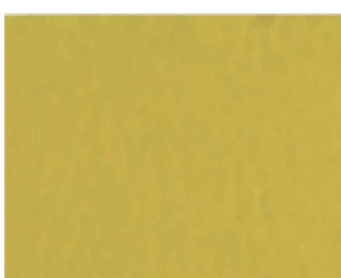

LIME / AL 926

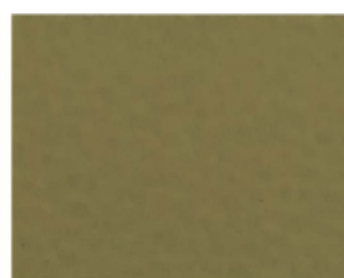

OLIVE / AL 927

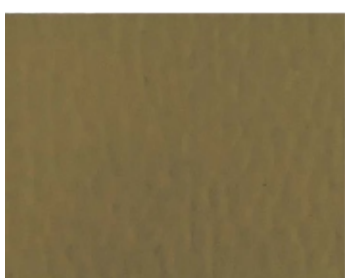

FERN / AL 928



ARMY / AL 929

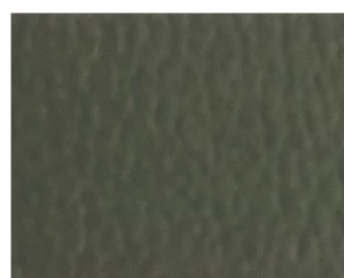

FOREST / AL 930

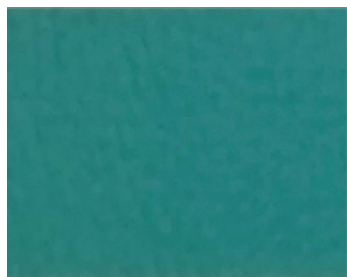

PINE / AL 931

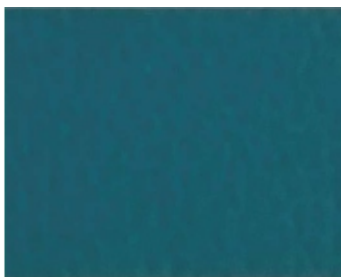

TURKISH / AL 932

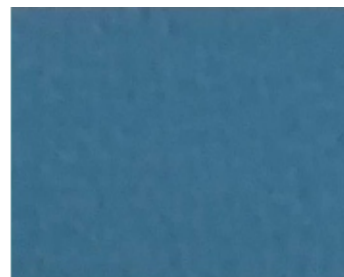

STEEL / AL 933

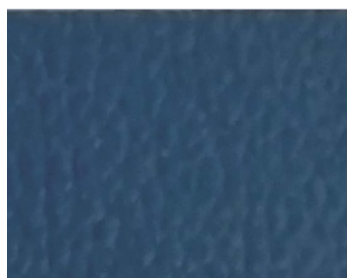

SPACE / AL 934

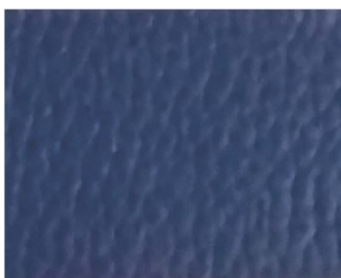

DENIM / AL 935



EGYPTIAN / AL 936

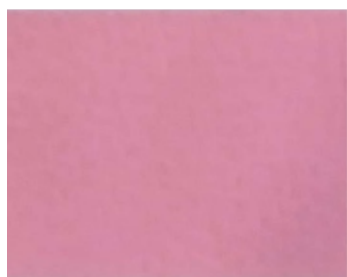

PUNCH / AL 937

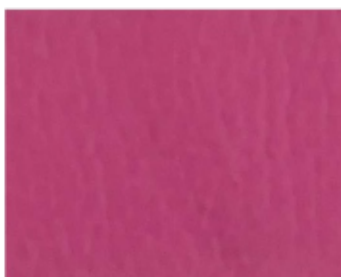

MULBERRY / AL 938



MAUVE / AL 939

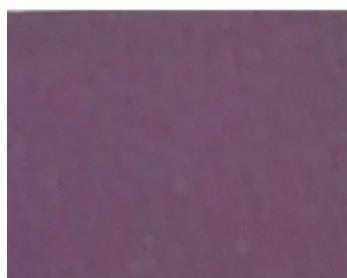

GRAPE / AL 940

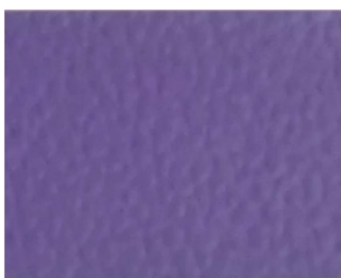

ORCHID / AL 941

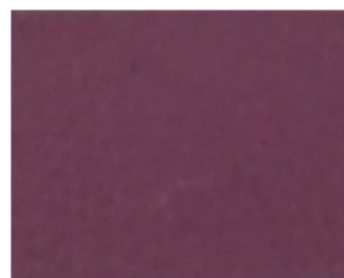

EGGPLANT / AL 942



SANGRIA / AL 943



SHADOW / AL 944

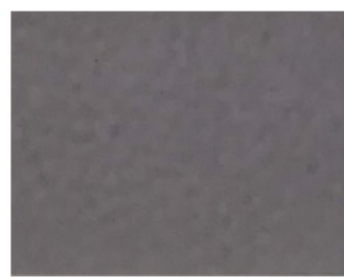

ANCHOR / AL 945



STONE / AL 946



IRON / AL 947

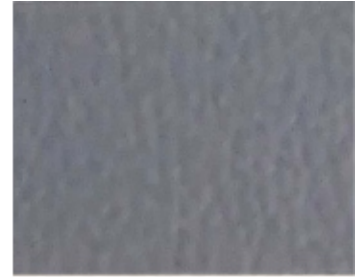

CHARCOAL / AL 948

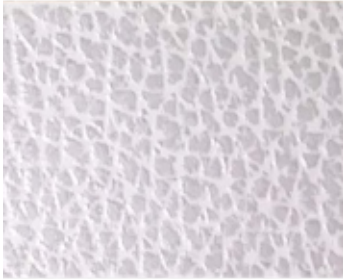

STATE / AL 701



BANANA / AL 702



LAVA / AL 703



BRICK / AL 704



BROWNIE / AL 705



RIVER / AL 706

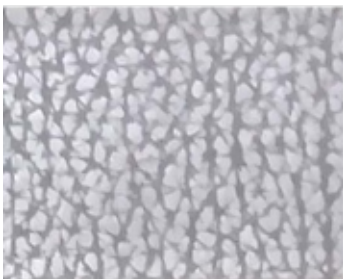

SILK / AL 707



BLACK / AL 949

Design	Width (In Cms)	Weight	Composition	Martin-Dale (Dry)	Martin-Dale (Wet)	Pattern Repeat (If any)
AL	137.2 ±	615 GSM	PU - 1%, PVC - 79%, FABRIC - 20%	25600 Cycles	6400 Cycles	N/A





SUNSHINE - AB 5001

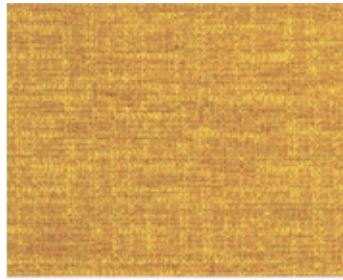

SUNSHINE - SD 5002

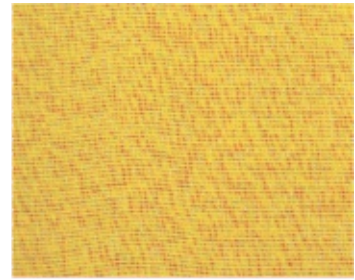

SUNSHINE - YZ 5003

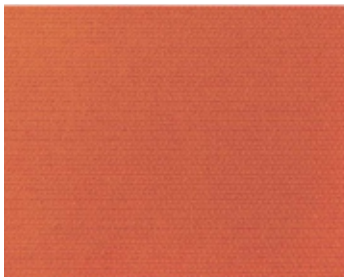

TANGO - AB 5004



TANGO - SD 5005



TANGO - YZ 5006

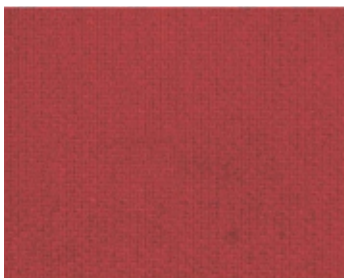

GARNET - AB 5007



GARNET - SD 5008



GARNET - YZ 5009

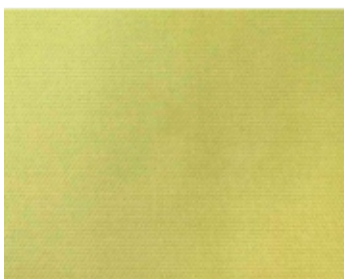

LEAF - AB 5010

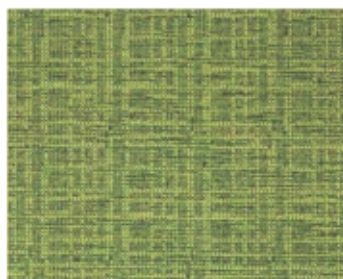

LEAF - SD 5011

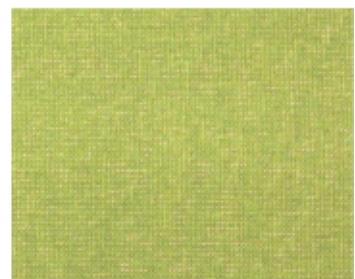

LEAF - YZ 5012

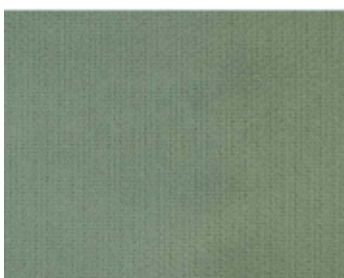

SEAFOAM - AB 5013

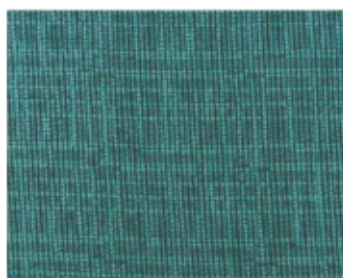

SEAFOAM - SD 5014



SEAFOAM - YZ 5015



PEACOCK - AB 5016

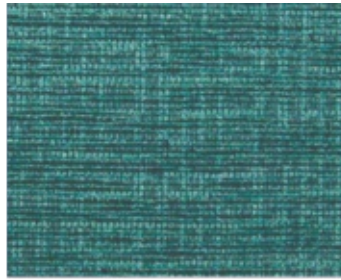

PEACOCK - SD 5017



PEACOCK - YZ 5018



OCEAN - AB 5019



OCEAN - SD 5020



OCEAN - YZ 5021

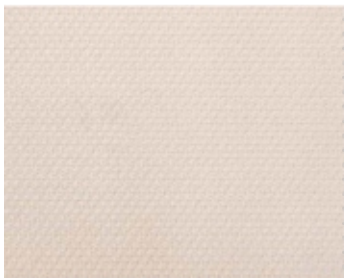

PORRIDGE - AB 5022

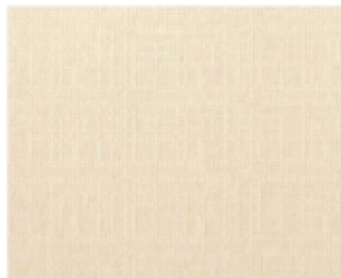

PORRIDGE - SD 5023



PORRIDGE - YZ 5024



ALLOY - AB 5025



ALLOY - SD 5026



ALLOY - YZ 5027

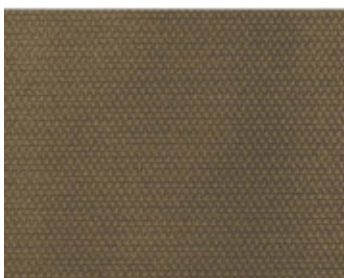

STONE - AB 5028



STONE - SD 5029



STONE - YZ 5030



TOBACCO - AB 5031



TOBACCO - SD 5032



TOBACCO - YZ 5033

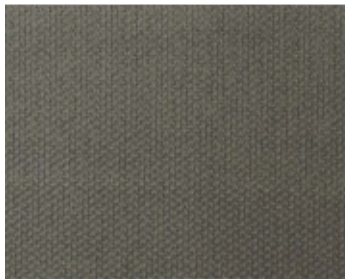

GUNMETAL - AB 5034



GUNMETAL - SD 5035



GUNMETAL - YZ 5036



CHARCOAL - AB 5037

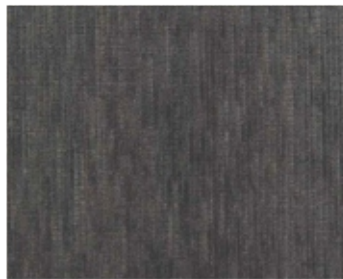

CHARCOAL - SD 5038



CHARCOAL - YZ 5039

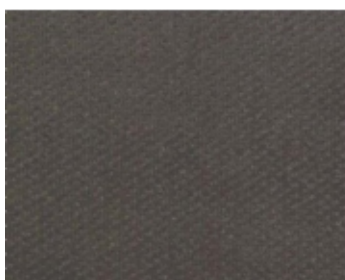

EBONY - AB 5040



EBONY - SD 5041



EBONY - YZ 5042

Design	Usage/Rubs	Composition	Col Code
AB	Heavy Commercial 120,000	100% Polyester	0
SD	Heavy Domestic / General Commercial	82% Polyester, 18% Polypropylene	0
YZ	Heavy Commercial 40,000	64% Polyester, 36% olefin	0



DOWNTOWN-M100



DOWNTOWN-M101



DOWNTOWN-M200



DOWNTOWN-M201

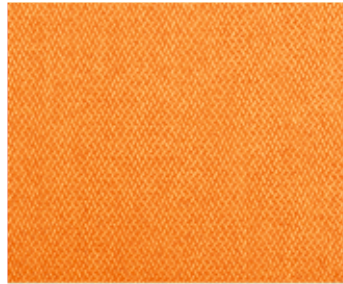

DOWNTOWN-M300



DOWNTOWN-M301

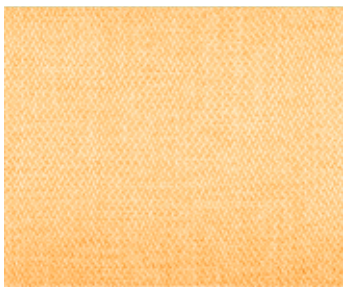

DOWNTOWN-M400



DOWNTOWN-M500



DOWNTOWN-M501

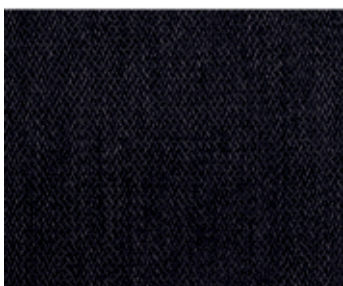

DOWNTOWN-M600

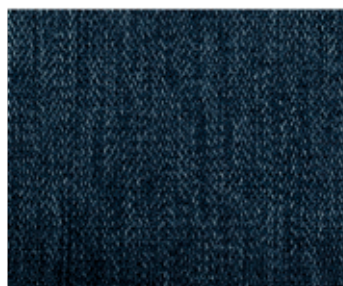

DOWNTOWN-M601



DOWNTOWN-M602



DOWNTOWN-M700



DOWNTOWN-M701



DOWNTOWN-M702



DOWNTOWN-M800



DOWNTOWN-M801



DOWNTOWN-M802



DOWNTOWN-M803



DOWNTOWN-M804



DOWNTOWN-M805

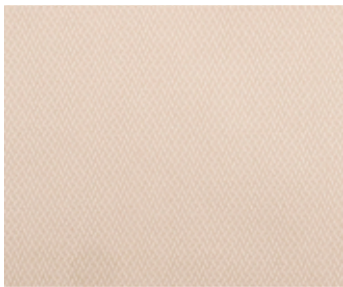

DOWNTOWN-M900

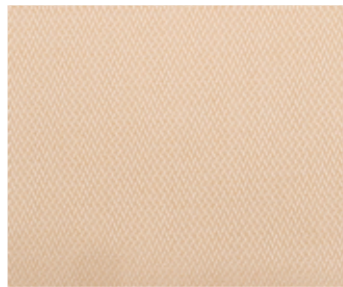

DOWNTOWN-M901



DOWNTOWN-M902



DOWNTOWN-M903



DOWNTOWN-M904



DOWNTOWN-M905

**Disclaimer:** This brochure is intended for general information, description and illustration of the Product including optional functions and equipment and may not be specific to a Product since specification of a product may change from time to time. Optional features, functions and equipment etc. may not be present in the Standard or Variant Product or Special Edition Product. Further, Standard specifications of a product may also vary from time to time. Colours may differ from those shown in pictures in the brochure, owing to printing. Shearling Skins Private Limited reserves the right to make changes, at any point of time, without prior notice, in design, colours, materials, components, equipment, specifications, features, functions, make and models etc. The information given in this brochure shall be regarded as accurate at the time of going to print and may vary thereafter due to any developments or any other reason. Interested parties should confirm with the Authorised Dealer or the parent Company about the correct specification of the product they desire to purchase. For the latest authentic information and updates, kindly contact your nearest Authorised Dealer or the Parent Company.

All title, ownership rights and intellectual property rights in and relating to this brochure / magazine or publication material or any copies thereof including but not limited to copyright, logos, names, trademarks, service marks, design, text, images, links, concepts and themes are owned by Daimler AG and/or its subsidiaries collectively or used under authorised license by the Shearling Skins Private limited . Any reproduction, transmission, publication, performance, broadcast, alteration, license, creation of derivative works or other use in whole or in part in any manner without the prior written consent of the Shearing Skins Private Limited is strictly prohibited.



## Shearling Skins Pvt Ltd

Plot No. 260, Sector-6  
IMT Manesar  
Gurgaon  
Haryana-122052  
Ph: +91 124 4037237  
info@shearling.in

[www.shearling.in](http://www.shearling.in)